

**DISCLAIMER FOR FRONT PAGE OF MATERIALS TO BE MADE AVAILABLE VIA ETI INTERNET SITE**

1. "Save to the extent set out in paragraph 2 below, this document and its contents are made available to you via the ETI's Internet Site "as is" without any representations, conditions, warranties or other assurance of any kind. The ETI and the authors, together with their employees, directors, servants or agents exclude to the maximum extent permissible by law all representations, warranties, conditions or other assurance whatsoever (whether express or implied) regarding the use of this document or its content including any warranties of title, merchantability, accuracy, completeness, non-infringement or that the document or its contents are of satisfactory or any particular quality or fit for any particular purpose. Any person accessing this document and using it or any of its contents accepts all risk in doing so.
2. Notwithstanding any statement to the contrary contained on the face of this document, the ETI confirms that the authors of the document have consented to its publication by the ETI."

## **ETI MA1001 - Reliable Data Acquisition Platform for Tidal (ReDAPT) project:**

### **ME8.2 'Final Experimental Design'**

**Date:** 24<sup>th</sup> November 2011

**Version:** 2.0

**Prepared by:** Dr Tom Vance & Tim Fileman

***Page left blank for double-sided printing***

## Contents

<b>Figures and Tables .....</b>	<b>4</b>
<b>Executive Summary .....</b>	<b>5</b>
<b>I Introduction .....</b>	<b>6</b>
1.1 Development of Experimental Design – Antifouling Testing .....	6
1.1.1 Fouling Heterogeneity .....	6
1.1.2 Variation in Fouling and Antifouling Performance at Device Scale .....	6
1.1.3 Damage and Loss of Samples .....	6
1.1.4 Coating Type.....	7
<b>2 Final Experimental Design .....</b>	<b>8</b>
2.1 Randomised Block Design .....	8
2.2 The Units of this Experimental Design .....	9
2.2.1 Test Panels.....	9
2.2.2 Coating Treatments.....	9
2.2.3 Test Panel Holders .....	10
2.2.4 Experimental Arrays .....	11
2.2.5 Benthic Pods .....	12
<b>3 Construction and Development of Test Arrays.....</b>	<b>15</b>
3.1 Design .....	15
3.2 Corrosion .....	15
3.3 Stability .....	15
3.4 Experimental Design Summary .....	15
<b>4 Background Data.....</b>	<b>16</b>
<b>5 Identification of Proxy Structures .....</b>	<b>17</b>
<b>6 Sampling and Analysis .....</b>	<b>18</b>
6.1 Antifouling Performance.....	18
6.1.1 Photography by ROV .....	18
6.1.2 Macrophotography .....	18
6.1.3 Image Analysis .....	18
6.1.4 Push off Adhesion Testing .....	18
6.1.5 Laser Profilometry .....	19
6.1.6 Coating Thickness.....	19
6.2 Hydrodynamic Data.....	19
6.3 Environmental Data .....	19
6.3.1 Physical Data .....	19
6.3.2 Light penetration .....	19
6.4 Data Analysis.....	19
6.5 Sampling Strategy.....	20
6.5.1 Device Mounted Test Panels .....	20
<b>7 Development of Experimental Design – Micro-Environment.....</b>	<b>22</b>
7.1 Introduction .....	22
7.2 Physical Damage - Approach.....	22
7.3 Wide Scale Disturbance - Approach .....	23
<b>8 Timeline .....</b>	<b>25</b>
<b>9 Summary.....</b>	<b>27</b>
<b>10 References.....</b>	<b>28</b>

## Figures and Tables

### Figures

Figure 1: Example of a balanced randomised block design. N=3 for each treatment type and the position of each replicate within treatment type is randomised.....	8
Figure 2: Test panel/plaque design.....	9
Figure 3: Image of the front of the Test Panel Holder for deployment on the TGL device. Note that this unit has handles to facilitate safe attachment and removal from the TGL Device. ....	10
Figure 4: Image of the back of the Test Panel Holder for deployment on the TGL device.....	11
Figure 5: Image showing arrangement on the port side of the device with mounting positions for 6 experimental arrays. ....	12
Figure 6: Image looking down on to the device showing the mounting positions of 6 experimental arrays (2 arrays are hidden from view in this image).....	12
Figure 7: Benthic Pod framework and full assembly including the Test Panel Holders.....	13
Figure 8: Chart of EMEC survey area around the TGL device. Blue tracks – previous ROV surveys, Red track – ROV survey of 11kV, Yellow track – cable to instrumentation pod, NSEW are key quadrat locations 100m from TGL turbine (EMEC pod to West and PML Benthic Pods to the South and East), Leg 1, 2, 3 – TGL turbine foundation legs.....	14
Figure 9: Image showing experimental blocks to be removed and kept in seawater during device downtime.....	21

### Tables

Table 1: Antifouling testing considerations, implications and threats to testing and mitigation measures...7	7
Table 2: Summary of Experimental Design.....	15
Table 3: Micro scale sampling summary.....	23

## Executive Summary

This document summarises the experimental design that will be used to test the efficacy of antifouling coatings as part of the ReDAPT programme and for application in the wider tidal renewable energy industry. The development of the experimental design is described in terms of the replication and distribution of sample coatings that is required to meaningfully test antifouling performance. The infrastructure that will be used to test the antifouling coating samples is discussed together with the position of samples relative to the TGL device. Sampling and analytical methods are described for measuring antifouling performance in addition to environmental data required to put fouling rates into perspective. Finally, the experimental design used to test for possible micro-scale disturbance generated by the TGL device is discussed including sampling methods, locations and analytical procedures.

# 1 Introduction

## 1.1 Development of Experimental Design – Antifouling Testing

In order to usefully test the performance of antifouling coatings for ReDAPT, the following aspects need to be considered in the experimental design. The aspects are discussed separately and then summarised in Table I along with the appropriate mitigation steps to ensure experimental rigour is applied.

### 1.1.1 Fouling Heterogeneity

The settlement of microorganisms and macroorganisms that constitute biofouling is influenced by many environmental, seasonal and spatial factors such as temperature, light and hydrodynamics. The relative influence of these factors is often difficult to predict and can vary over small temporal scales (seconds) and spatial scales (mm – cm). Consequently, fouling is often very variable over a scale of meters and is subject to patchiness which reflects the variation in the factors that influence settlement.

When designing an experiment to test antifouling performance, it is not adequate to base conclusions on low sample numbers taken from one location. This approach is very likely to lead to non-representative conclusions that do not reflect the performance of a coating in the full range of conditions it will experience whilst in operation.

### 1.1.2 Variation in Fouling and Antifouling Performance at Device Scale

The environmental factors that influence the fouling process, particularly light levels and hydrodynamics will vary over the device surface making some areas more prone to faster rates of fouling than others. It is also likely that the different fouling species associated with niche areas will require different cleaning efforts to remove them should fouling occur (in spite of antifouling coatings being applied). Antifouling coating chemistry, and the resulting performance, can be influenced by light and hydrodynamic regimes and it is very likely that variation in performance within coating type will be seen across the device.

For these reasons it not sufficient to base conclusions on antifouling performance from samples taken on one area of the device surface. Samples should be taken from around the device including niche areas to fully understand the suitability of each coating type to the marine tidal turbine application.

### 1.1.3 Damage and Loss of Samples

Measuring antifouling coating performance for use in tidal energy applications requires deploying and maintaining test panels *in-situ* for at least 24 months. This is challenging due to the fast tidal flow (up to 7 knots) and high risk of damage to coatings and experimental infrastructure caused by collision with large objects such as logs etc. This damage could result in the loss of several test panels or the loss of an entire array. Further damage to the antifouling coatings could occur during the deployment and recovery of the device itself during routine maintenance together with separate recovery and deployment of the antifouling panels for sampling.

Being able to withstand considerable collision damage and possible scouring is a requirement of a successful coating for renewable energy applications. However, it is important to differentiate between coating failures that occur as a result of deployment and

recovery from those that occur from damage *in-situ*. Understanding where and how damage occurs will inform both optimum deployment procedures together with optimum coating choice for different areas of the device surface.

### 1.1.4 Coating Type

There is considerable variation in antifouling coating technology (see ME8.I report) on the market in terms of overall performance, the mechanism that determines performance, the expected lifespan and service intervals. Consequently, it is a requirement to test a variety of antifouling coatings that spans the available technology in order to determine which coating is most suitable for the renewables application.

**Table 1: Antifouling testing considerations, implications and threats to testing and mitigation measures**

Testing consideration	Implication / Threat	Mitigation
Fouling heterogeneity	<ul style="list-style-type: none"> <li>• Unrepresentative results</li> <li>• Patchy performance</li> <li>• Unclear conclusions</li> </ul>	<ul style="list-style-type: none"> <li>• Test multiple replicates of each coating</li> <li>• Distribute replicates to minimise the effect of variable uncontrolled factors</li> <li>• Perform separate tests on benthic landers exposed to different environmental conditions.</li> </ul>
Variation in fouling and antifouling performance at device scale	<ul style="list-style-type: none"> <li>• Unrepresentative results</li> <li>• Patchy performance</li> <li>• Unclear conclusions</li> </ul>	<ul style="list-style-type: none"> <li>• Test multiple replicates of each coating</li> <li>• Distribute replicates to minimise the effect of variable uncontrolled factors</li> <li>• Test performance on different locations around the device</li> </ul>
Damage and loss of samples	<ul style="list-style-type: none"> <li>• Loss of replicate samples leads to unclear conclusions</li> <li>• Total lack of data</li> <li>• No differentiation between <i>in-situ</i> and deployment/recovery damage leads to inappropriate coating choice</li> </ul>	<ul style="list-style-type: none"> <li>• Test multiple replicates of each coating</li> <li>• Distribute replicates so that damage is unlikely to remove all samples of one coating type</li> <li>• Perform tests on different locations around the device</li> <li>• Perform separate tests on benthic landers to increase chance of undamaged samples surviving</li> </ul>
Coating type	Not choosing / testing the most appropriate coating	Test multiple technology types/brands



## 2 Final Experimental Design

### 2.1 Randomised Block Design

Section I clearly shows that meaningful antifouling testing for ReDAPT requires the following:

- Testing multiple coating types
- Testing suitable numbers of replicates of each coating type to reduce the effect of uncontrolled environmental factors
- Distributing replicates to limit data loss resulting from damage
- Testing antifouling performance at multiple locations on the TGL device
- Testing antifouling performance on alternative structures

Consideration of these requirements has led to the following experimental design being adopted which is based on the tried and tested principle called the balanced randomised block design. Using this approach, replicate samples of the same coating type are randomly arranged in blocks with equal numbers of other coating types.

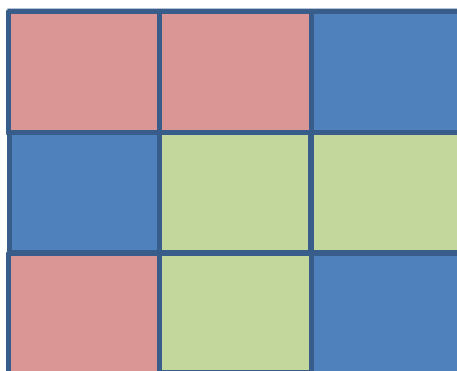

**Figure 1: Example of a balanced randomised block design. N=3 for each treatment type and the position of each replicate within treatment type is randomised.**

This approach is frequently used by field biologists as it allows the experimenter to measure a response (antifouling performance or percentage cover of fouling species) which may be subject or influenced by multiple uncontrolled factors ([Bailey, R. A 2008](#)).

In addition this approach provides:

- Enough replication to reduce the effect of uncontrolled factors
- Produces discrete, independent replicates that allow for robust statistical analysis
- Allows each experimental array to be considered as a stand-alone experiment in the event of loss of other array resulting from damage
- Equal numbers of treatments and controls to allow for strong statistical analysis (balanced design) which to detect subtle differences between coating performance
- Sufficient replication to allow for loss or damage within each experimental array
- The possibility to combine or pool replicates across arrays to greatly improve statistical power, if no statistically significant difference is measured between experimental arrays.

## 2.2 The Units of this Experimental Design

### 2.2.1 Test Panels

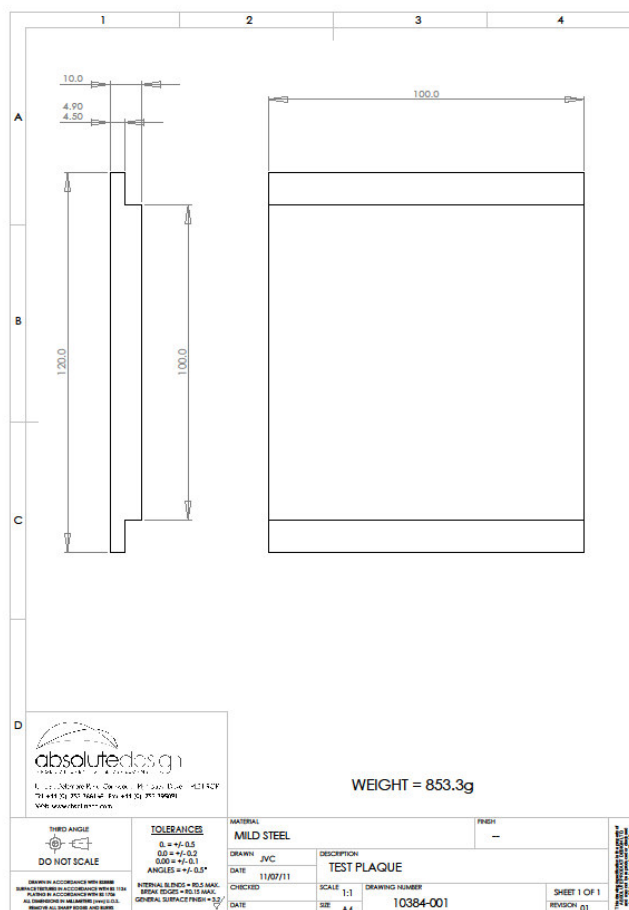

Figure 2: Test panel/plaque design

- These panels are made of mild steel to replicate the material used to construct the device
- The panels have a machined edge to hold them firmly in the panel holders (described below)
- The panels are coated in an anticorrosive, tie coat and antifouling top coat (provided and applied by the respective antifouling manufacturers)

### 2.2.2 Coating Treatments

The treatments, or coating types, being tested in the experiment are being supplied by the manufacturers listed below. The exact list of products being tested is not yet finalised and most manufacturers are constantly updating products, and are keen to be testing the flagship product when the testing starts. However, the coatings to be tested will represent a good spread of different coating types, including biocidal and non-biocidal technologies, from the world's largest suppliers together with some smaller firms.

All coatings will be applied to the test panels by the coating manufacturers to ensure that application is of a high standard and does not interfere with performance. Manufacturers that have given 'in principal' support are:

- International Paint Ltd
- ECOSPEED
- Jotun
- Hempel
- PPG
- HSF
- Whitford
- Coppercoat

The TGL device is expected to be coated with a hard epoxy coating supplied by Jotun which provides excellent mechanical damage resistance and high visibility but does not have a specific antifouling capability other than being smooth and exhibiting a low surface energy after application. The performance of this coating will be monitored at the same time as the test coatings that are being deployed on the device.

Consultation with manufacturers is underway in an attempt to seek agreement for the manufacturers to apply coatings to niche areas of the device such as the blades and the nose cone. It is hoped that three manufacturers can be persuaded to apply their respective coatings to the blades and the nose cone on the device.

If negotiations with the manufacturers are successful, one non-biocidal low surface energy coating (likely to be Intersleek 900 from International Paint Ltd) will be trialled against two biocidal copper based antifouling coatings (likely to be Coppercoat and an Jotun product TBA), These coatings will be arranged in three strips with a different coating making up each strip on the blades (tip, middle and base of the blade) and each coating covering one equal third of the nose cone.

### 2.2.3 Test Panel Holders

The Test Panel Holders hold test panels securely in place and have been designed to:

- Securely fix ten replicate test panels in place
- Insulate test panels from direct metal to metal contact between different metal types to prevent corrosion
- Allow easy deployment and recovery on the device
- Withstand substantial collision impacts from water borne debris

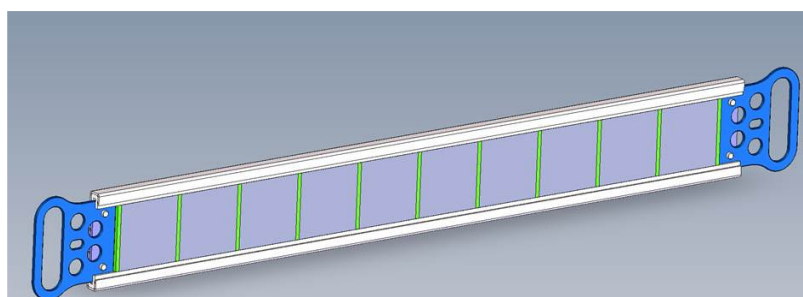

**Figure 3: Image of the front of the Test Panel Holder for deployment on the TGL device. Note that this unit has handles to facilitate safe attachment and removal from the TGL Device.**

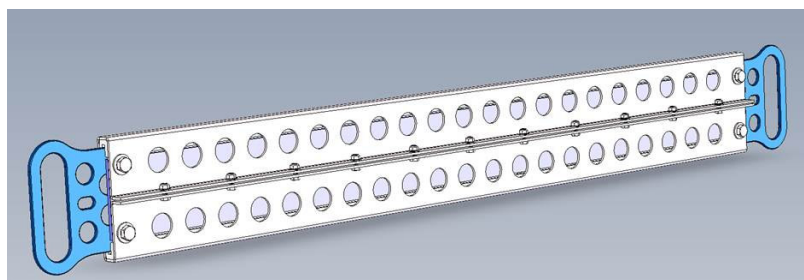

**Figure 4: Image of the back of the Test Panel Holder for deployment on the TGL device**

The Test Panel Holders shown above are designed to be directly mounted on the device and include handles to allow safe and easy removal from the device. Separate Test Panel Holders will be constructed as shown above but without handles for deployment on the Benthic Pod. These Test Panel Holders will not be removed until the end of the experiment and don't require handles.

#### 2.2.4 Experimental Arrays

The Test Panel Holders will be arranged one above the other in blocks of five which create an experimental array consisting of 50 individual test panels, randomly arranged. The 50 test panels will be made up of the following:

- 5 replicates of 7 different coatings types ( $7 \times 5 = 35$ )
- 5 replicates of a control surface (non-antifouled anticorrosive coating)
- 5 panels from Sheffield University for metal corrosion testing
- 5 contingency panels – to be used either for another coating or for destructive sampling to confirm species identification.

Each experimental array contains sufficient replication of each coating type to be considered a standalone experiment. This design provides a high level of redundancy as it is unlikely that all the experimental arrays (6 on the Device and 4 on the Benthic Pods) will be compromised during the deployment.

The antifouling performance of each coating will be analysed within each individual array to provide an idea of performance under the unique conditions each array will be exposed to. Performance of each coating will also be compared between arrays. If no statistically significant difference is measured between arrays, the replicates may be pooled to produce high sample sizes which have more statistical power.

Statistical power is useful for detecting subtle differences in performances between coatings. This robust experimental design produces data that can be analysed a number of different ways which provides flexibility and redundancy that will allow antifouling performance to be assessed even if some losses of panels and damage occurs.

##### 2.2.4.1 Arrangement of Experimental Arrays

Six experimental arrays will be mounted directly on the device as shown by the blue rectangular areas in the device picture below (Figures 5 & 6).

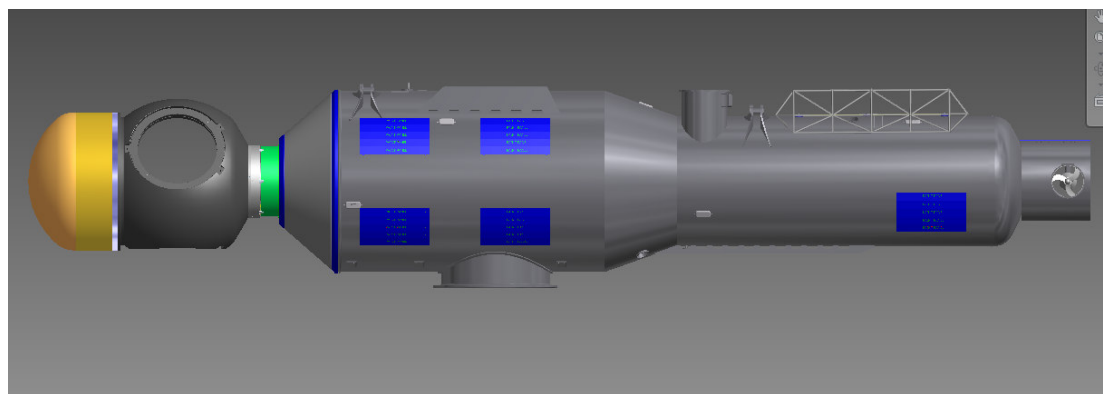

**Figure 5: Image showing arrangement on the port side of the device with mounting positions for 6 experimental arrays.**

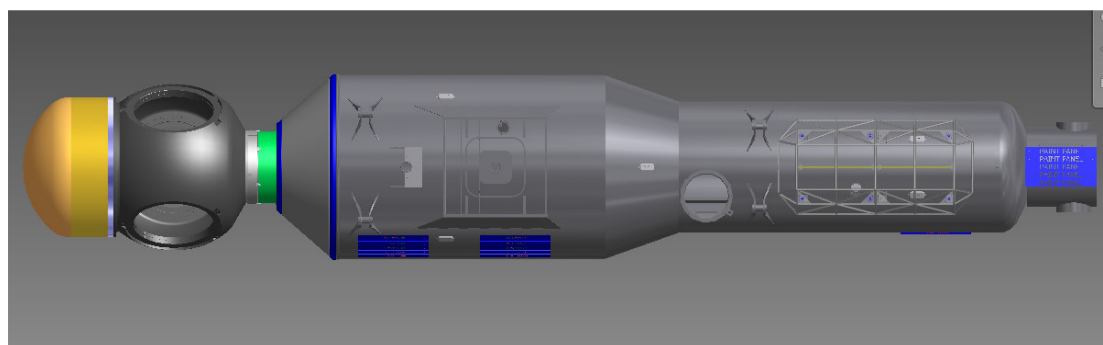

**Figure 6: Image looking down on to the device showing the mounting positions of 6 experimental arrays (2 arrays are hidden from view in this image).**

The arrangement of the experimental arrays on the port side of the device was dictated in part by the device deployment and recovery requirements. The device comes into contact with the recovery vessel on the Starboard side and so all arrays were mounted on the port side in an attempt to avoid damage.

The arrangement of the arrays on the device is designed to provide data from areas of the device expected to receive high turbulence behind the blades and areas that would receive less turbulence towards the rear of the device. Arrays are also arranged on the top side and the bottom side of the device to allow comparison between different light exposures. The array positioned above the thruster was included as this is considered to be a high priority area which could experience different hydrodynamic activity compared to the rest of the device.

### 2.2.5 Benthic Pods

The antifouling test panels mounted on the TGL device offered the most valuable test platform as they will experience the exact hydrodynamic and light regime that antifouling coatings used for this application will be required to endure. However, focusing performance testing only on the panels on the device would not be wise because:

1. The device could be subject to technical problems which prevent sufficient time in the water to collect meaningful fouling data
2. The operational profile of a prototype device is likely to be very different to that of a device in full operation.

3. The device is likely to incur mechanical damage during repeated deployment and recovery
4. It is useful to understand how antifouling performance works at different light levels/ depths as not all marine tide generators will be of the TGL design

In order to address these issues it was decided that further testing should be conducted on separate Benthic Pods as shown below. These pods are made up of a stainless steel frame which supports panel holders of the same design describe earlier.

These pods meet the contractual requirements of testing antifouling performance at different depths and conditions to the main device. The pods will be positioned in 35 m of seawater compared to the 15m depth of the test panels fixed to the device. Additionally, the pods provide four separate, standalone, experiments which add redundancy to the testing programme and serves to considerably reduce the risk of data loss.

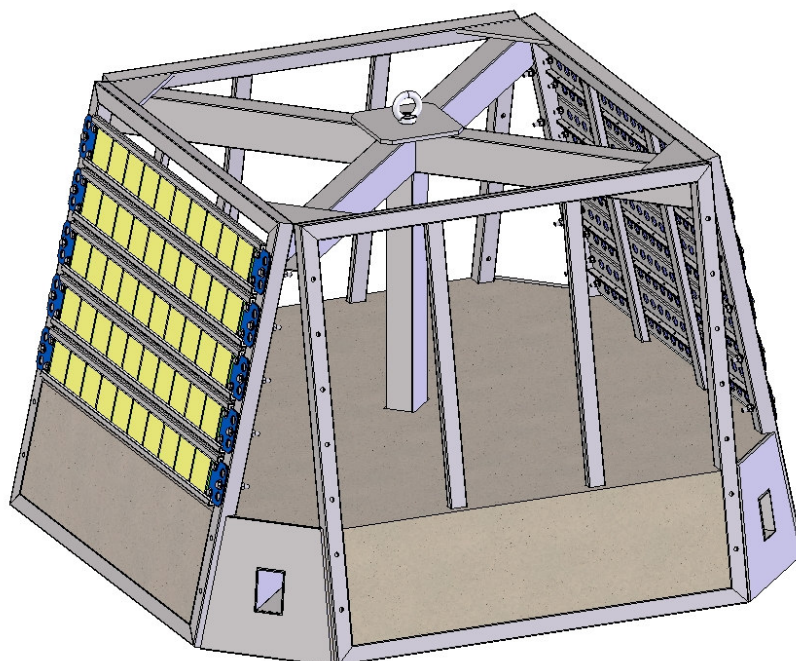
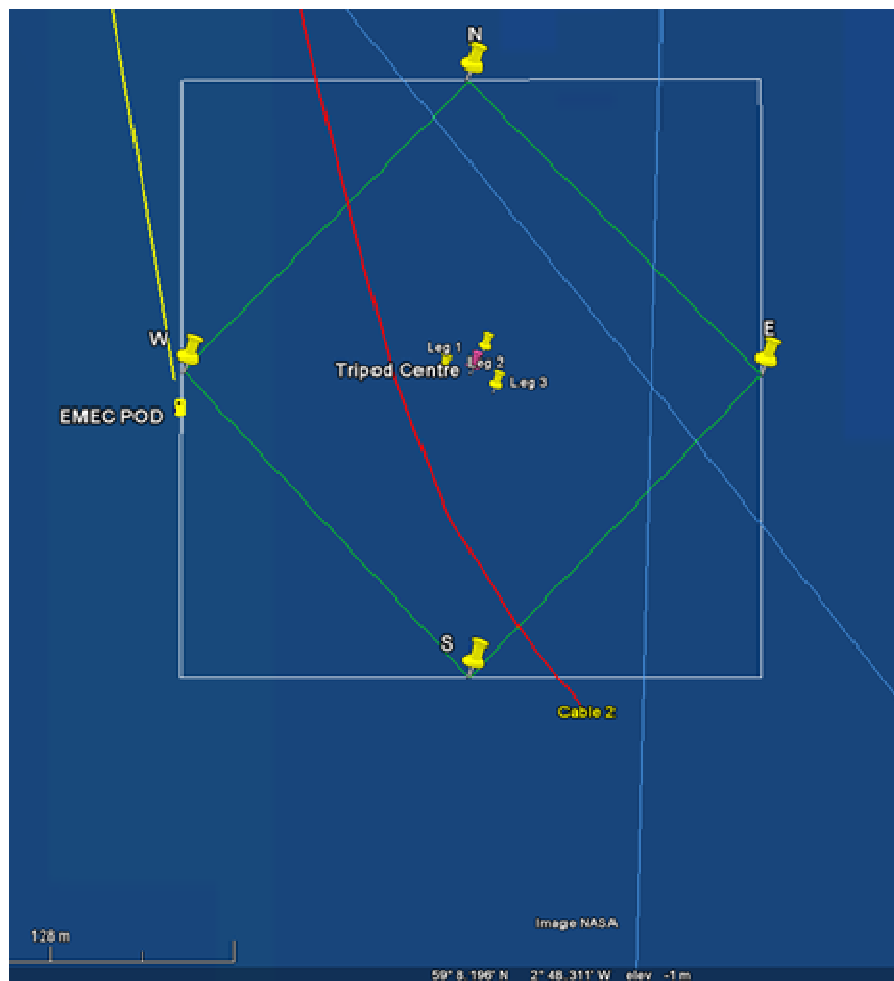

**Figure 7: Benthic Pod framework and full assembly including the Test Panel Holders**

#### 2.2.5.1 Benthic Pod Positions

The Benthic Pods will be positioned at the end of the two cardinal point transect lines that make up the six monthly ROV survey area which is being monitored by EMEC in the near field (Figure 8). This positioning is advantageous because:

- The Benthic Pods can be visually sampled with the EMEC ROV which increases sampling resolution by providing time series data
- Allows regular checks to be made of the Benthic Pods to ensure they are in place
- Greatly reduces deployment and recovery costs



**Figure 8: Chart of EMEC survey area around the TGL device. Blue tracks – previous ROV surveys, Red track – ROV survey of 11kV, Yellow track – cable to instrumentation pod, NSEW are key quadrat locations 100m from TGL turbine (EMEC pod to West and PML Benthic Pods to the South and East), Leg 1, 2, 3 – TGL turbine foundation legs.**

## 3 Construction and Development of Test Arrays

### 3.1 Design

The design of the testing infrastructure has been conducted by a design company commissioned by PML as a result of the ReDAPT Design Review process. The design has been reviewed according to the ReDAPT requirements and feedback from the design review process has been worked into the final design presented in this report.

### 3.2 Corrosion

Corrosion was identified as a specific risk to this testing as the original design had mild steel and stainless steel potentially coming into direct contact. Consultation with Dr Robert Edyvean (a marine corrosion expert) at Sheffield University resulted in a modification to the design so that each metal type is insulated from making contact with a different metal type with plastic insulating strips separating the test panels from the panel holders.

### 3.3 Stability

Keeping the benthic pods in position despite the strong tidal flow is vital to ensure that the test conditions the antifouling coatings are exposed to are known and also to ensure successful recovery of the panels at the ends of the experiment. In order to manage this risk, the pods were constructed to meet with the seabed stability requirements provided by Rolls Royce by adding a concrete base to the pods.

### 3.4 Experimental Design Summary

The final experimental design consists of testing 500 test panels. The panels will be arranged into the experimental arrays as described above. The experimental arrays will be distributed between the Benthic Pods described above and the device itself as shown in the breakdown below.

**Table 2: Summary of Experimental Design**

	<b>Number of Test Panels</b>	<b>Number of Panel Holders</b>	<b>Number of Experimental Arrays</b>
<b>Device</b>	300	30	6
<b>Benthic Pods – 2 per Pod</b>	200	20	4



## 4 Background Data

In order to predict and quantify fouling performance on the test coatings, information is required on background fouling conditions. This information helps to answer the following:

- Which fouling species are likely to be encountered on the device?
- When do peak settlement seasons occur?
- Does the fouling encountered during the experiment represent typical conditions in the test site?

This information is very useful for deciding which coatings to test and whether some coating technologies work more effectively against particular fouling species than others. In addition, this information provides context for the experiment to ensure that test conditions replicate normal environmental conditions. Understanding seasonality of fouling is important when scheduling cleaning and maintenance programs to ensure that maximum efficiency in cleaning effort is achieved.

At the time of project conception, much of this information was to be obtained from deploying a very basic array supporting non-antifouled panels (or controls) late in 2011 and maintaining it in the field until early 2012. A variation request will be submitted to change this deployment based on the following:

- Consultation with Andrew Want and Joanne Porter of Herriot Watt University confirmed that these experts in local settlement biology already have on-going sampling regimes that will provide the type of data required to answer the background questions required for the ReDAPT programme
- The time series data both scientists have collected is likely be of far greater value than a one year sample that was originally planned as part of ReDAPT
- By making the most of on-going sampling by local experts, more resource was available to focus on the main testing of coatings *in-situ*. This resource was not inconsiderable with the deployment and recovery of even a basic array being likely to cost a minimum of £4000.
- The very basic arrays that were envisaged in the original proposal would not have withstood the environmental conditions that they were to be deployed in.
- It is doubtful whether any useful or robust information would have been forthcoming from such a deployment.

## 5 Identification of Proxy Structures

The main focus of our antifouling performance testing will be on both the TGL device and the Benthic Pods. However, additional information can be gained from external collaborations and surveying exposed hard substrates in the vicinity.

Information will be gathered from collaboration with expert biologists working in the Orkney Islands. This will include information about settlement rates and seasonality of fouling species on hard substrata on local beaches and ports which are already part of monitoring programs. In addition, PML are planning to deploy settlement panels in Kirkwall Marina to complement the existing marina surveys being conducted in Stromness by Joanne Porter.

Since the start of the project PML have been working closely with EMEC and TGL who have been very helpful in supplying pictures of fouling as they encounter it on a variety of structures and after different deployment durations. These include the TGL 500KW device, surface buoys and benthic ADCP Pods. PML has carried out detailed examination of TGL photographs and EMEC equipment that has been deployed in or near the test site. This has provided information on species identification together with fouling rates.

The varied range of equipment being deployed in ReDAPT means that fouling data will be available from a variety of materials including stainless steel, epoxy coatings and plastics. Much of the fouling information on these materials is expected to come from the ADCP deployments that are occurring throughout the near-field and far-field sites together with the EMEC environmental monitoring pod.

PML has requested that all parties in ReDAPT supply pictures of fouling on their respective equipment together with depth and duration details. This information has been limited to date but is expected to increase as the project gets underway and equipment deployments and recoveries occur.

## 6 Sampling and Analysis

### 6.1 Antifouling Performance

Antifouling performance will be determined by quantifying which species are present on coated panels after deployment. The percentage cover of each species present will also be measured to produce relative abundance data for comparison between coating types.

#### 6.1.1 Photography by ROV

*In-situ* images of test panels on the Benthic Pods will be collected by the ROV during surveys as described. ROV footage will also be used to analyse antifouling performance of the panels attached directly to the device during six monthly ROV surveys. Although ROV footage is unlikely to be very high resolution, the image quality should be sufficient for crude percentage cover values to be made at six monthly intervals. This time series data will provide important information that may allow loss of antifouling performance over time to be measured. Additionally, the collection of time series data with the ROV provides data securities against panels that maybe lost or damaged and are not available for end point analysis. A protocol for photographically sampling the panels will be sent to TGL prior to deployment.

#### 6.1.2 Macrophotography

High resolution digital macro photographs will be taken of test panels on the Benthic Pods after recovery at the end of the experiment (12 months exposure in the field). This will provide high quality data for measuring percentage cover and species identity of fouling species that will allow determination of antifouling performance between coatings.

Macro photography will also be used to record fouling on test panels when they are recovered from the device during service intervals. The exact time scale of this data capture is unknown as the device recovery timetable is likely to change. Any time series data that can be collected at these service intervals is of value and the exact timing is not critical. In addition to the time series data, test panels will be photographed at the end of the device deployment to provide end point data

#### 6.1.3 Image Analysis

Both still images from ROV footage and macro photographs will be analysed using ImageJ™ software. This standard practise is well published and provides an efficient method to quantify image area and then record percentage cover and relative abundance of fouling species present. Images are first standardised for size, cropped and filtered. A grid is then arranged over the image with 100 dots placed evenly over the image. The species present (or free unfouled space) underneath each dot is recorded and percentage coverage data is produced for analysis.

#### 6.1.4 Push off Adhesion Testing

Adhesion of barnacles that settled on the test panels will be measured using a push of force gauge. This gauge will measure how strongly barnacles were adhered to the coating and provide important information that will inform cleaning and maintenance requirements.

### 6.1.5 Laser Profilometry

A sub-set of the test panels from each experimental array will be examined with laser profilometry both before and after deployment. This technique will allow the roughness of the coating to be quantified using a high precision laser. Roughness is a measure of the abrasion that the coating experienced during deployment. As the tidal device is subject to rapid tidal flows, the ability of the coating to withstand abrasion (not just physical but chemical too) over time is expected to be a major criteria by which suitable coatings for the tidal industry are selected. The laser technique will also provide measure of larger scale collisions that occur from larger water borne debris.

### 6.1.6 Coating Thickness

We will also apply another technique to measure the coating thickness on the same subset of samples both before and after deployment of the panels. Thickness information is very important as it can be used to measure the life expectancy of many coating types. The coating thickness information together with the laser profilometry will allow the useful life expectancy of a coating used on tidal devices to be calculated thus providing valuable information to device developers.

## 6.2 Hydrodynamic Data

Hydrodynamic data will not be measured directly by PML; however the complex hydrodynamic data being collected by ReDAPT partners will provide more than sufficient information to describe the hydrodynamics in the test environment.

Consultation with Ian Bryden at University of Edinburgh has confirmed that ADCP measurements taken both on the device and in the far field area will be able to feed data into our analysis. This will provide information describing:

- the flow over the test panels on the benthic pods and the TGL device
- the turbulence over the panels on the TGL device
- attempt to characterise how much solid suspended matter is present at the test site which could cause abrasion (this may include soft non-damaging particles).

## 6.3 Environmental Data

### 6.3.1 Physical Data

Environmental data consisting of salinity, temperature and pH will be measured by EMEC and will provide the environmental data to parameterise growth rates and settlement time of fouling species.

### 6.3.2 Light penetration

Light penetration will be measured during the micro environment analysis described below.

## 6.4 Data Analysis

The exact analytical processes that will be used depend on the final data that is collected but it is anticipated in advance of project completion that Plymouth Routines In Multivariate Ecological Research (PRIMER) software will be used to measure:

- Time series fouling species data will be analysed with ANalysis Of SIMilarity (ANOSIM)
- Multi Dimensional Scaling (MDS) plots will be used to compare fouling severity between coating types over time on test panels
- SIMilarity PERcentages (SIMPER) test will be used to identify which species contribute most to the fouling present on each coating.
- Principal Component Analysis (PCA) will be used to understand which of the variables measured (light, flow, turbulence) was most important in determining fouling percentage cover and ultimately antifouling performance.

## 6.5 Sampling Strategy

Type /Location of Samples	Method of Sampling	Time of Sampling
Panels on the TGL Device	<ul style="list-style-type: none"> <li>• Macro photography</li> </ul>	<ul style="list-style-type: none"> <li>• On final retrieval of experiment (12 months deployment)</li> </ul>
Panels on the TGL Device	<ul style="list-style-type: none"> <li>• Push off testing</li> </ul>	<ul style="list-style-type: none"> <li>• On final retrieval of experiment (12 months deployment)</li> </ul>
Panels on the TGL Device	<ul style="list-style-type: none"> <li>• Macro photography</li> </ul>	<ul style="list-style-type: none"> <li>• During device recovery (times to be announced)</li> </ul>
Panels on the TGL Device	<ul style="list-style-type: none"> <li>• ROV footage</li> </ul>	<ul style="list-style-type: none"> <li>• Six monthly ROV Survey</li> </ul>
Panels on the Benthic Pods	<ul style="list-style-type: none"> <li>• Macro photography</li> </ul>	<ul style="list-style-type: none"> <li>• On final retrieval of experiment (12 months deployment)</li> </ul>
Panels on the Benthic Pods	<ul style="list-style-type: none"> <li>• Push off testing</li> </ul>	<ul style="list-style-type: none"> <li>• On final retrieval of experiment (12 months deployment)</li> </ul>
Panels on the Benthic Pods	<ul style="list-style-type: none"> <li>• ROV footage</li> </ul>	<ul style="list-style-type: none"> <li>• Six monthly ROV Survey</li> </ul>
Hydrodynamic data (near field, far field and around the device)	<ul style="list-style-type: none"> <li>• ADCP as per ReDAPT plan</li> </ul>	<ul style="list-style-type: none"> <li>• Continuous after deployment</li> </ul>
Environmental data	<ul style="list-style-type: none"> <li>• EMEC environmental pod</li> </ul>	<ul style="list-style-type: none"> <li>• Continuous after deployment</li> </ul>

### 6.5.1 Device Mounted Test Panels

Being able to withstand prolonged exposure out of the water is a requirement of an antifouling coating that is suitable for the tidal renewable energy industry. Device down time and operational profiles are not yet known for many device types and exposure to air, heat fresh water (rain) and light during device down time is inevitable. The TGL device will be in and out of the water during the antifouling test period and this presents several challenges/opportunities when attempting to measure antifouling performance:

- Exposure to atmospheric air, light, heat and fresh water (rain) can all affect antifouling coating performance by altering biocide release etc.
- Subtidal fouling species will be sensitive to atmospheric air, light, heat and fresh water (rain) and may perish. This is good and bad because:

- The effects on biofouling and coatings of repeated exposure to atmosphere need to be quantified
- Device manufacturers will require continuous exposure data on coatings

When measuring antifouling performance it is important to be able to differentiate between unfouled areas of coating produced by the coating's antifouling properties and those produced by the death and removal of fouling species (caused by prolonged exposure to air during operational down time of the device).

This challenge is being addressed by treating the test panels on the device differently when the device is taken out of the water during operational down time. The 3 experimental arrays circled in red below (Figure 9) will be removed from the device when the device is taken out of the water. The experimental arrays that are being removed from the device will be suspended in seawater in the dock to keep any fouling present on the panels alive during downtime. A log sheet will be supplied by PML to allow TGL to easily record panel removal durations and conditions.

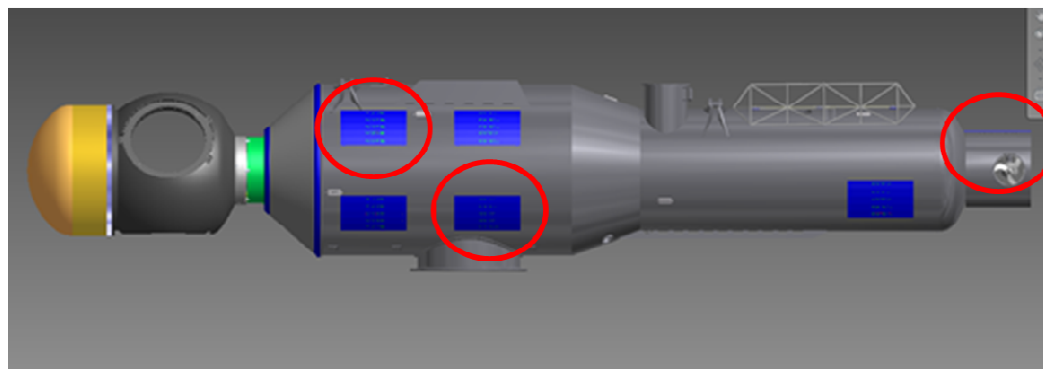

**Figure 9: Image showing experimental blocks to be removed and kept in seawater during device downtime**

This removal and preservation procedure will allow the effect of exposure to air during device downtime on antifouling performance to be measured. It also allows the continuous antifouling performance of the coatings that remained in position on the device to be measured.

The Benthic Pods are expected to experience continuous deployment at the test site with no interruption during testing, however, the difference in depth between the Benthic Pods and the device (~ 20 m) means that, although very useful, the results *may* not be directly transferable with those recorded on the device. Consequently, the removal of some experimental blocks during device down time is seen as a good alternative to ensure that the true antifouling performance of the test coatings is measured under the range of conditions that would be expected during a tidal device operational profile.

## 7 Development of Experimental Design – Micro-Environment

### 7.1 Introduction

Under the ME8 work package in ReDAPT, PML is contracted to provide data that will help to discover if the operation of the TGL device produces measurable impacts on the micro environmental scale. It is possible that operation of the device could:

1. Cause physical damage to pelagic microorganisms via the blades or other moving parts
2. Provide hydrodynamic disturbance in the test site which could alter environmental or physical conditions such as increasing dissolved oxygen concentration, re-suspending sediments (and nutrients) and increasing organic loading in the water. This could cause a shift in plankton community structure. This has been measured near off shore wind farms as reported in by Brostrom 2008 and caused by upwelling of nutrient rich water caused by surface wind currents facilitating blooms of plankton.

Either of these two scenarios have the potential to alter the viability (caused by physical damage), distribution or community structure of zooplankton, phytoplankton and bacteria in suspension in the water column downstream of the device. In order to address these questions, the following experimental design and sampling strategy was developed.

### 7.2 Physical Damage - Approach

A plankton net (200µm) will be deployed from a vessel adjacent to the device (outside the safety zone but in the same body of water). The net will be deployed to collect a vertical profile of plankton as close to the device as determined by the safe working practice produced by EMEC. A multi parameter data logger will also be used to record *in-situ* DO (Dissolved Oxygen), pH, salinity and depth. This will be repeated three times and the plankton samples (zooplankton) will be washed from the net and fixed in 4% buffered formalin. Additional 250ml whole water samples (for microplankton) will be collected and fixed in 1% Lugol's iodine solution and 2ml samples will be fixed in paraformaldehyde and frozen -20°C (pico- and nanoplankton).

The same operation will also be conducted immediately downstream of the device, while the device is operational. Again, proximity to the device will be determined by EMEC.

All samples will be returned to PML for observation and enumeration. Zooplankton and microplankton communities will be enumerated using a combination of stereo and inverted light microscopy or FlowCAM. Pico and nanoplankton abundance will be determined using analytical flow cytometry.

These procedures will provide data to describe:

- The community structure of pelagic plankton

- The physical condition of individuals (how many partial or broken organisms are present per unit volume)
- The community structure of the microorganisms in the water upstream and downstream of the device
- The physical condition or viability of the microorganisms in the water upstream and downstream of the device.

### 7.3 Wide Scale Disturbance - Approach

In order to understand if the device is having a wider scale effect on the pelagic plankton and microorganisms, multiple data points are required. The pelagic microbial and planktonic community will vary in response to fluctuations in environmental variables such as DO and nutrient loading (both natural and potentially caused by the device). Therefore repeated sampling is required to differentiate between natural variation and effects of the device.

If repeated data points describing plankton community structure and viability show consistent differences between water influenced by the turbine and not, it is reasonable to assume the device is altering the wider scale micro environment and a more detailed investigation is warranted in addition to the work carried out in this ReDAPT study.

Sampling will be informed by far-field ADCP data and will consist of the same method as described above but with sampling being repeated 3 times within a week (or as close to a week as weather conditions allow) and at increasing distance downstream of the device. The sampling will be conducted during the spring or summer 2012 when plankton abundance is expected to be high.

**Table 3: Micro scale sampling summary**

Location of Samples	Method of Sampling	Time series
Control Site - Upstream of the EMEC site (in the same water that flows through the site)	<ul style="list-style-type: none"> <li>• 3 x plankton vertical profiles</li> <li>• 3 x water samples</li> </ul>	<ul style="list-style-type: none"> <li>• Repeated three times over 3 days</li> </ul>
Downstream of the device during operation	<ul style="list-style-type: none"> <li>• 3 x plankton vertical profiles</li> <li>• 3 x water samples</li> </ul>	<ul style="list-style-type: none"> <li>• Repeated three times over 3 days</li> </ul>
	<b>Total plankton tows samples = 18</b> <b>Total water samples = 18</b>	

The information provided by the micro-scale sampling outlined here will be sufficient to discover whether the turbine is having a significant and measurable impact on micro scale environmental health. It is possible that natural, seasonal, variation in planktonic community structure will influence the potential for the turbine to disrupt normal conditions in the test site. However, there is not scope within this study to perform a long and detailed survey of the area.

It is important to address questions about large scale impacts before large arrays of tidal devices are constructed. However, it is considered that the level of disturbance caused by a



turbine blade is likely to be negligible compared to damage that would routinely occur as a result of ship propeller blades that travel at much greater speeds and cause cavitation.

## 8 Timeline

The experimental approach described in this report is scheduled to take place according to the following time plan.

ME8.2	Month / Year	Development of experimental design, construction and deployment of test arrays / identification of proxy structures:
1	Sep-11	Identify and agree collaboration with on-going fouling studies to identify key species / fouling seasonality
2	Sep-11	Seek permission for deployment of control (PVC) panels in local marinas to provide background fouling data
ME8.3	Month / Year	Deploy and monitor antifouling test panels on the TGL device and on Benthic Pods. Sample water upstream and downstream of TGL device for micro scale environmental assessment.
3	Nov-11	order Construction of arrays (benthic pods and test panel holders)
4	mid-Nov	Panels off to paint companies
5	end-Dec	Kit from manufacturer & Coated test panels & get kit ready for deployment
6	Jan-12	Conduct laser profilometry
7	Feb-12	Transfer of Device Test Panel Holders complete with coated panels to RR (Dunfermline?)
8	Feb-12	Transfer kit to Orkney & Deployment of pods at two sites by EMEC followed by confirmation of deployment by ROV if possible
9	Mar-12	Analysis of biofouling organisms on structures (main species / biomass estimates) - EMEC ROV quarterley Video and device when out of water
10	Apr-12	Liaise UoE over far and near field flow characterisation results
11	Apr-12	Initiate water sampling at Falls of Warness for identification of planktonic/microbial organisms
12	Apr-12	Intensive field monitoring of water column biological and physico-chemical parameters over tidal cycle
13	Apr-12	Net tows and CTD (with PAR) survey in turbine turbulence (outside safety zone) and in clean flow past turbine
14	Apr-12	Collect samples for analytical flow cytometry, planktonic analysis and physico-chemical parameters
15	From deployment	Inspect TGL device and associated infrastructure whenever removed from the site (photos requested of any gear removed from site)
16	Aug-12	Interim progress report including evaluation of adequacy of sampling protocols and methods to undertake micro-scale impact assessment monitoring.
ME8.4	Month / Year	Analysis and synthesis of results, interpretation and recommendations
16	Ongoing	Analysis of biofouling organisms on structures (main species / biomass estimates) - EMEC ROV Video and device when out of water
17	Apr-13	Recover arrays from Device
18	Apr-13	Recover Benthic Pods and associated Arrays & Push-off testing
19	Apr-13	Transfer of samples to PML (and / or use of photographic evidence where appropriate)
20	Apr-13	Analysis of biofouling of test arrays recovered (photography)
22	May-13	Laser profilometry

23	May-13	Analysis of biofouling on panels
24	Jun-13	Collation of experience / results from other sources (eg. Wave Hub site)
25	Jun-13	Results of analytical flow cytometry, planktonic analysis and physico-chemical parameters
26	Jun-13	Statistical analysis and interpretation of results
27	Aug-13	Report - Summary of results from bio fouling analysis / plus micro scale impacts analysis and interpretation.
<b>ME8.5</b>	<b>Month / Year</b>	<b>Analysis and synthesis of results, interpretation and recommendations</b>
28	Dec-13	Final report

## 9 Summary

Fouling is variable and significant gradients of fouling severity can occur across small spatial scales. Consequently, a robust measurement of antifouling performance requires replication of samples and distribution of replicates in such a manner that firm conclusions can be drawn about antifouling performance. The approach to antifouling testing described in this document achieves this and also builds in the considerable contingency of samples required when working in an extreme environment where there is a very high risk of losing samples. The range of coating brands and technology types being tested under a variety of conditions makes these experiments being conducted for ReDAPT the most advanced test of antifouling coatings for the tidal industry known to-date. The micro-scale environmental testing described in this report will provide timely evidence of how tidal devices affect micro-scale environmental health and indicate if this area requires further research effort prior to the development of wide scale tidal arrays.

## 10 References

Bailey, R. A (2008). *Design of Comparative Experiments*. Cambridge University Press. ISBN 978-0-521-68357-9. <http://www.maths.qmul.ac.uk/~rab/DOEbook/>.

Brostrom, G. (2008) *On the influence of large wind farms on the upper ocean circulation*. Journal of Marine Systems, 74, 586-598.



Registered Office:  
Prospect Place, The Hoe,  
Plymouth, PL1 3DH,  
United Kingdom

T +44 (0)1752 633100  
F +44 (0)1752 633101  
W [www.pml.ac.uk](http://www.pml.ac.uk)  
E [forinfo@pml.ac.uk](mailto:forinfo@pml.ac.uk)

Plymouth Marine Laboratory (PML)  
is a NERC Collaborative Centre.  
Registered charity number 1091222.  
PML is a company limited by guarantee,  
registered in England & Wales,  
company number 4178503.